

## How an Ecovector® fan convector works

Hot water from your central heating system passes through the heat exchanger transferring its heat to the aluminium fins. Cooler air is drawn in by the fan and heated as it passes through the heat exchanger before being Expelled gently back into the room. Fan convectors use around 25% less energy than a radiator to heat up a room, give a more even temperature spread and achieve the required temperature in much less time.

This heater includes a selectable low temperature cut out thermostat (set by your installer dependant on the type of heat generator) that prevents the fan from operating until the central heating system water passing through the heat exchanger reaches 38° for renewable systems or 52C for boiler systems. This prevents **Ecovector®** circulating cooler air at start up.

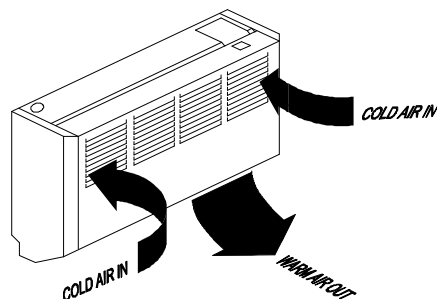

## Heating

Ensure your central heating system is on, the heat output switch set to normal **I** and the fan-only switch set to RED (Heating). Providing the water temperature in the system is more than 38°C and the thermostat/s controlling your central heating system is calling for heat your heater will switch on.

If you require a faster warm up move the heat output switch to boost **II**. moving the heat output switch to **0** will turn off the heater.

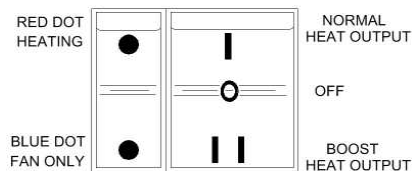

## Air Circulation (summer use)

Ensure central heating is off. Set the fan-only switch to **BLUE** and the heat output switch to either **I** or **II**. **Ecovector®** will run to provide a cooling flow of air. If the heater is being used in conjunction with a room thermostat, the thermostat must be set to maximum.

## Fault Finding

This heater is covered by a free five-year parts and labour guarantee. Please refer to the fault finding section of the installation guide for advice. In the event of difficulty please contact us on 01245 324560. it will be helpful if you do not disconnect the heater from the central heating system.

### Smith's Environmental Products Ltd,

Blackall Industrial Estate, South Woodham Ferrers, Chelmsford Essex CM3 5UW

Tel: 01245 324900 After Sales: 01245 324560 Fax: 01245 324422

E-mail: [info@smiths-env.com](mailto:info@smiths-env.com) Web: [www.smiths-env.com](http://www.smiths-env.com)

For Ireland (Republic & Northern), contact MT Agencies on 00 353 1 864 3363

In light of our policy of continuous development Smith's Environmental Products Ltd reserve the right to alter specifications without prior notice.



Versatile, energy efficient heating

## ECOVECTOR® High Level Fan Convectors

Models

HL 1000, HL 1000-12V  
HL2300, HL2900, HL4000

## INSTALLATION & USER GUIDE

Dear Installer,

The following items should be included in the carton:

- Product complete with cable
- Transformer (HL 1000-12V only)

**In the event of items missing or visible damage please contact us on 01245 324560. We would be most grateful if you would leave this Installation & User Guide and the Guarantee Registration Card with the owner of the property.**

Thank you for your co-operation.

Steve Russell  
Technical Services Manager

## Introduction

This heater is primarily intended for installation onto a wall at high level. The maximum recommended installation height is 2.1 metres to the underside of the heater. There is no clearance required above or to the side of the heater.

Electrical installations for these heaters must only be carried out by a suitably qualified person.

### Model HL 1000-12V

This model is designed for use in bathrooms and other high humidity areas. For these applications it is essential that the heater, transformer and fused spur are installed in line with current regulations relative to fixed current equipment in high humidity areas, wet rooms and/or bath and shower rooms.

The transformer has been designed to fit into a surface-mounted or recessed pattress box (not supplied) similar to those used for shaver sockets (47mm deep). The transformer can be mounted horizontally or vertically however it must not be directly above the heater but should be accessible after completion of the installation.

Supply to the transformer must be via a 3 amp fused spur. The fused spur must not be directly above the heater but should be accessible after completion of the installation. Twin core cable is fitted to the product for connection to transformer. HL 1000-12V should not be earthed

### Models HL 1000, HL 2300, HL 2900 & HL 4000

These models must not be installed in bathrooms or other high humidity areas.

**Ecovector**<sup>®</sup> is classified as a fixed appliance and electrical connection should be via a 3A-fused spur. The fused spur must not be directly above the heater but should be accessible after completion of the installation. If the pre-wired mains cable is damaged it must be replaced by the manufacturer, its service agent or similarly qualified persons. This appliance must be earthed.

For models HL 2900 and HL 4000 we recommended that when securing the product to the wall two persons should lift the heater into position.

### All models

These heaters are designed for use on standard two-pipe pumped central heating systems. Pipes are 15mm for models HL 1000, HL 1000-12V, HL 2300, HL 2900 and 22mm for model HL 4000. Either pipe may be used as flow or return. These heaters are not suitable for one-pipe systems.

We recommend the use of full flow isolating valves. The valves should be accessible after completion of the installation. We also advise the fitting of an air vent at the highest point on either the flow or return pipe to remove any air trapped within the system.

To avoid the possibility of vibration these heaters must be fitted on a flat even surface.

To conform to Building Regulations Part L (Part J in Scotland) these **Ecovector**<sup>®</sup> heaters can be controlled by a remote wall mounted room thermostat (Smith's Environmental Products Part No. RT002). For further details please contact us on 01245 324560.



**Versatile, energy efficient heating**

## **ECOVECTOR<sup>®</sup> High Level Fan Convector**

### **Models**

**HL 1000, HL 1000-12V  
HL2300, HL2900, HL4000**

## **USER GUIDE**

Dear Customer,

We are delighted you have chosen one of our products and trust you are satisfied with the installation. We would ask you to take a few minutes to read the User Guide to help you gain maximum benefit from your Ecovector<sup>®</sup> fan convector. As with all our products your **Ecovector**<sup>®</sup> is covered by a free five-year parts and labour guarantee and we would be grateful if you complete and return the Guarantee Registration Card to us as soon as possible. This will ensure that should you require assistance we can deal with you quickly and efficiently.

Thank you for your co-operation.

Steve Russell  
Technical Services Manager  
01245 324900

P.s Your **Ecovector**<sup>®</sup> is designed to operate as part of your central heating system in the same way as a panel radiator. Providing you leave the heat output switch in either the normal I or boost position II and the fan-only switch set to RED your **Ecovector**<sup>®</sup> will switch on and off automatically with your central heating system.

Heat output performance continued from page 5

Heat outputs are tested in accordance with BS4856. The temperature of the water in the Central heating system will affect the heat output of this heaters.  $\Delta t$  60°C assumes a Mean water Temperature of 80°C and a room temperature of 20°C.  $\Delta t$  50°C assumes a mean water temperature of 70°C and a room temperature of 20°C.  $\Delta t$  20°C assumes a Mean water Temperature of 40°C and a room temperature of 20°C.

## Fault Finding

1. Fan does not run on any switch setting.
  - a. Check the power supply is turned on.
  - b. Check the fuse in the fused spur.
  - c. Check the wiring connections at the fused spur.
2. No heat output on settings **I** or **II**.
  - a. Vent any trapped air from the system (with the central heating system turned OFF).
  - b. Check the central heating is turned ON.
  - c. If fitted ensure the room thermostat is calling for heat.
  - d. Balance the central heating system if installed on the same circuit as panel radiators and increase the circulating pump speed if required.
  - e. Increase the boiler water temperature.

**In the event of difficulty please contact us on 01245 324560. It will be helpful if you do not disconnect the heater from the central heating system.**

***This appliance is not intended for use by persons (including children) with reduced physical, sensory or mental capabilities, or lack of experience and knowledge, unless they have been given supervision or instruction concerning use of the appliance by a person responsible for their safety. Children should be supervised to ensure that they do not play with the appliance.***



Products with this symbol (crossed out wheellie bin) cannot be disposed as household waste. Old electrical and electronic equipment must be recycled at a facility capable of handling these products and their waste by-products. If you are purchasing replacement equipment your retailer may offer a 'take back' scheme, or will be able to give details of the nearest approved authorised treatment facility. Proper recycling and waste disposal will help conserve resources whilst preventing detrimental effects on our health and the environment.

WEEE Registered Code: WEE/ED0093VW

**Smith's Environmental Products Ltd,**

Blackall Industrial Estate, South Woodham Ferrers, Chelmsford Essex CM3 5UW

Tel: 01245 324900 After Sales: 01245 324560 Fax: 01245 324422

E-mail: [info@smiths-env.com](mailto:info@smiths-env.com) Web: [www.smiths-env.com](http://www.smiths-env.com)

For Ireland (Republic & Northern), contact MT Agencies on 00 353 1 864 3363

In light of our policy of continuous development Smith's Environmental Products Ltd reserve the right to alter specifications without prior notice.

## Installation

Please note the guarantee may be invalidated if this product is not installed and used in accordance with this guide.

1. Release the outer casing by removing the screws on the underside of the casing.
2. Secure heater to the wall using fixings suitable for wall and level. If necessary use packing to compensate for uneven wall surfaces. Maximum recommended installation height is 2.1 metres to the underside of the heater. For models 2900 & 4000 we recommend that two persons should lift the heater into position.

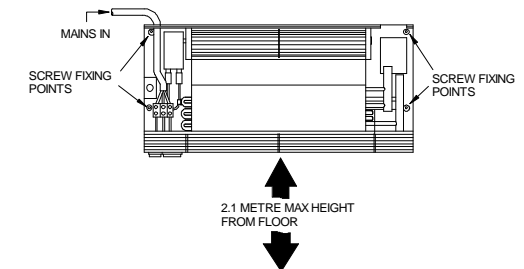
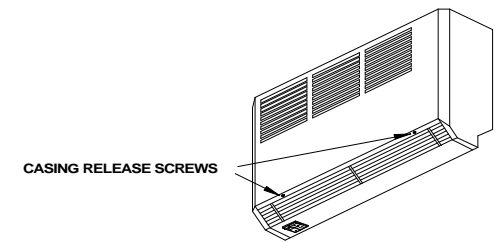

3. Connect the heating system flow and return pipes to the heater pipe work. Do not use soldered fittings to the heater pipe work as the heat generated could damage internal wiring and components. We recommend the use of full flow isolating valves. The valves should be accessible after completion of the installation. We also advise the fitting of an air vent at the highest point on either the flow or the return pipe to remove any air trapped within the system. Check for water leaks. Vent any trapped air from the heating system.

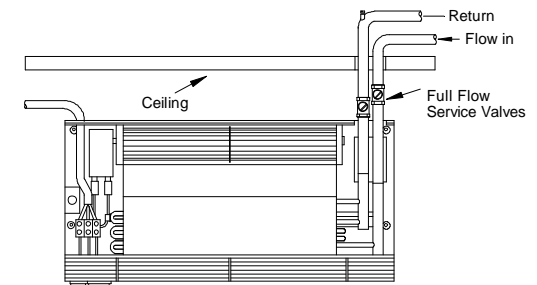

## Installation Continued. – Electrical connection

### Models HL 1000, HL 2300, HL 2900, HL4000

Electrical installations for these heaters must only be carried out by a suitably qualified person. All electrical installation connections must comply with BS7671, 1992 and IEE Regulations. Check the voltage on the heater is correct supply for your supply, if in doubt, consult a qualified electrician.

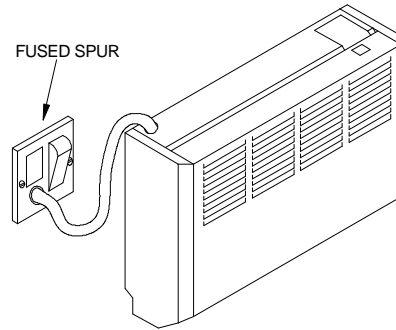

- Isolate the electrical supply and connect the heater electric cable to the spur (3A). The fused spur must not be directly above the heater but should be accessible after the installation is complete.

### Model HL 1000-12V

This model is designed for use in bathrooms and other high humidity areas. For these applications it is essential that the heater, transformer and fused spur are installed in line with current regulations relative to fixed current equipment in high humidity areas, wet rooms and/or bath and shower rooms. Electrical installations for these heaters must only be carried out by a suitably qualified person. All electrical installations must comply with BS7671, 1992 and IEE Regulations. Check the voltage on the heater is correct for your supply. If in doubt, consult a qualified electrician.

The supplied transformer has been designed to fit into a surface-mounted or recessed pattress box (not supplied) similar to those used for shaver sockets (47mm deep). The transformer can be mounted horizontally or vertically however it must **not** be directly above the heater but should be accessible after completion of installation.

Supply to the transformer must be via a 3 amp fused spur. The fused spur must **not** be directly above the heater but should be accessible after completion of the installation. HL 1000-12V should not be earthed.

- Isolate the electrical supply and connect the mains side of the transformer to the fused spur.
- Connect between the 12V side of the transformer and the heater using twin core cable fitted to the product.

## Installation Continued. – Final Assembly

- Refit the outer casing to the chassis attaching the earth bonding connector (not model HL 1000-12V) to the outer casing.

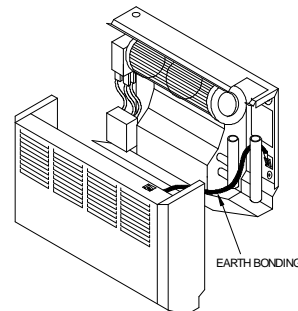

## COMMISSIONING

This heater is equipped with a selectable low temperature cut out thermostat which requires the correct system hot water to be sensed before the fan(s) will run. The heat source switch can be set to run on either renewable (38° C) or boiler or boiler mode (52° C).

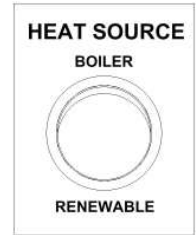

- Turn on electrical supply at the fused spur.
- Set the left hand (fan-only) switch to the blue dot and the right hand (heat output) switch to **II**, the fan should run at boost speed.
- Turn on the central heating system.
- Set the room thermostat (if fitted) to maximum.
- Set the left hand (fan-only) switch to the red dot and the right hand (heat output) switch to **I** or **II** – heat will flow within a few minutes.
- Balance the central heating system if the heater is installed on the same circuit as panel radiators.
- If the installation is working correctly remember to reset the room thermostat (if fitted) to its normal setting.
- Please leave this installation & user guide with the property owner for future reference

## Heat Output Performance

It is recommended that the Ecovector® High Level model is capable of maintaining The calculated heat losses at normal heat output (I) enabling the boost settings (II) to be Used for faster heat up.

Model	Heat Output Δt					
	60°C		50°C		20°C	
	Normal kW (Btu/h)	Boost kW (Btu/h)	Normal kW (Btu/h)	Boost kW (Btu/h)	Normal kW (Btu/h)	Boost kW (Btu/h)
HL 1000	1.0 (3500)	1.4 (4700)	0.9 (3100)	1.1 (3800)	0.4 (1300)	0.5 (1800)
HL 2300	2.3 (7800)	3.1 (10500)	1.9 (6400)	2.5 (8500)	0.9 (3000)	1.2 (4000)
HL 2900	2.9 (10000)	4.2 (14500)	2.5 (8500)	3.5 (12000)	1.1 (3800)	1.6 (5500)
HL 4000	4.0 (13500)	5.3 (18000)	3.3 (11300)	4.4 (15100)	1.5 (5100)	2.0 (6800)
HL 1000-12V	1.0 (3500)	1.4 (4700)	0.9 (3100)	1.1 (3800)	0.4 (1300)	0.5 (1800)

Continued on Page 6